

Dimensions and Weights



Turbine type: N29-225kW
Tower type: 40 meter6/2/2009 NH40/T 5 004 Rev. 002

The tower is in two sections, so each section is defined as Bot. Sec and Top sec.

Bottom Section see fig. 1

Bottom flange:	∅	3390 mm	133.46 Inches (")	11.12	Feet
Mid flange:	∅	2233 mm	87.91 Inches (")	7.33	Feet
Length of sec.:		19000 mm	748.03 Inches (")	62.34	Feet
Weight of sec.:		14000 kg	30864.71 Pound (lb)	15.43	Ton (US short)

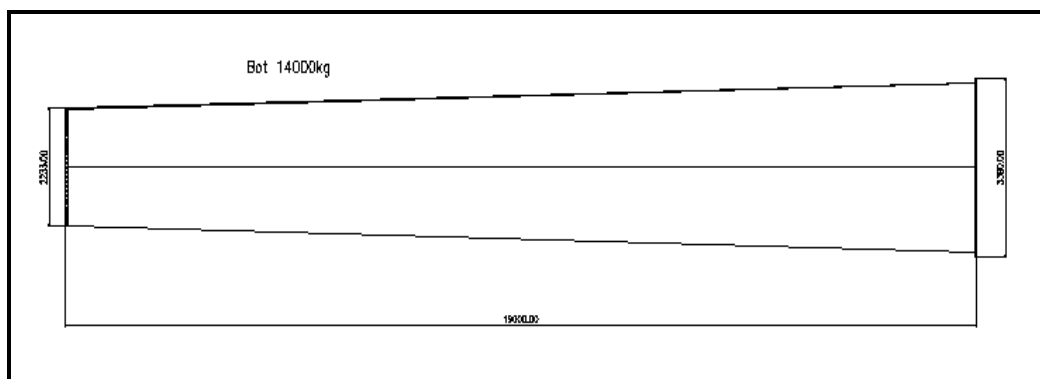

Top Section see fig. 2

Mid flange:	∅	2233 mm	87.91 Inches (")	7.33	Feet
Top. flange:	∅	1230 mm	48.43 Inches (")	4.04	Feet
Length of sec.:		19700 mm	775.59 Inches (")	64.63	Feet
Weight of sec.:		6500 kg	14330.05 Pound (lb)	7.17	Ton (US short)

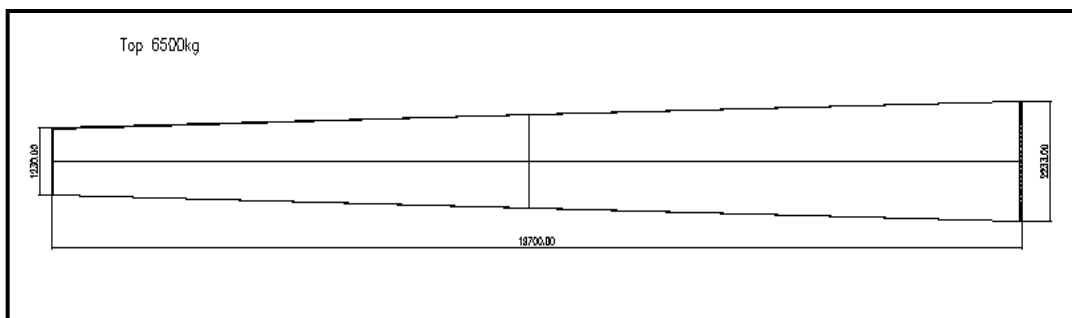

Nacelle:

The nacelle is mounted with main frame, main axle, gearbox, generator, top unit, yaw drive and various small parts.

Dimensions on nacelle:

Width:	2129 mm	83.82 Inches (")	6.98	Feet
Height:	2135 mm	84.06 Inches (")	7.00	Feet
Length:	3869 mm	152.32 Inches (")	12.69	Feet
Weight:	6500 kg	14330.05 Pound (lb)	7.17	Ton (US short)

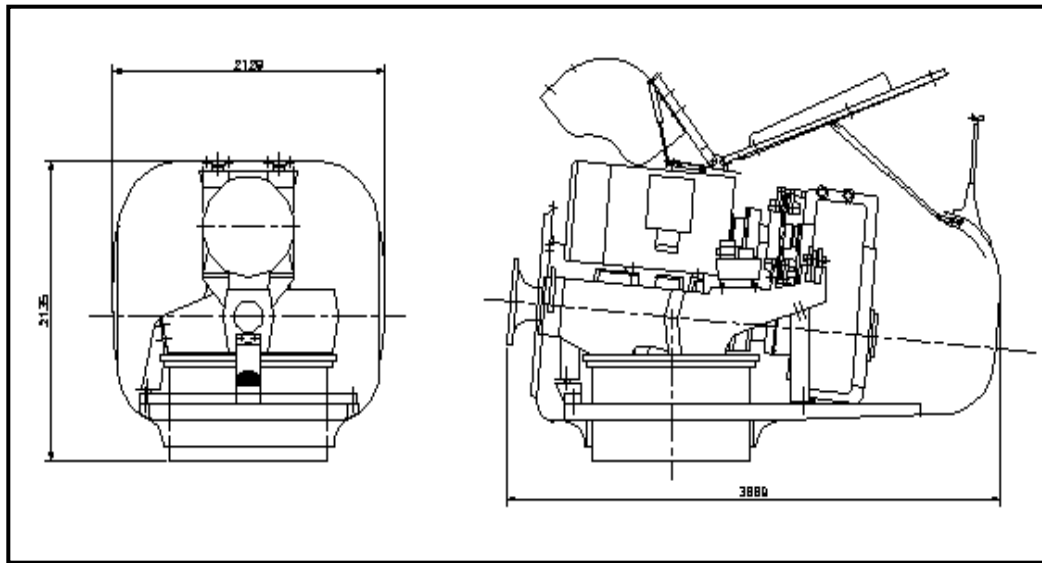

Hub:

Dimensions on hub:

Diameter:	∅	2370 mm	93.31 Inches (")	7.78	Feet
Height:		1997 mm	78.62 Inches (")	6.55	Feet
Width:		2302 mm	90.63 Inches (")	7.55	Feet
Depth:		680 mm	26.77 Inches (")	2.23	Feet
Weight:	ca.	1320 kg	2910.102 Pound (lb)	1.46	Ton (US short)

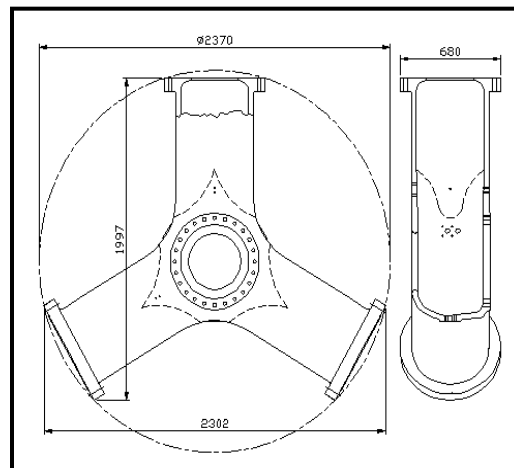

Blades:

Blade type: LM13,4 HHT

The blades are transported as set, which means 3 pieces

Dimensions on blades:

Diameter on root:	∅ 675 mm	26.57 Inches (")	2.21	Feet
Length:	13400 mm	527.56 Inches (")	43.96	Feet
Weight:	760 kg	1675.513 Pound (lb)	0.84	Ton (US short)

Controller cupboard:

Dimension on cupboard:

Depth:	500 mm	19.69 Inches (")	1.64	Feet
Height:	2100 mm	82.68 Inches (")	6.89	Feet
Width:	1300 mm	51.18 Inches (")	4.27	Feet
Weight:	200 kg	440.9245 Pound (lb)	0.22	Ton (US short)